

Memo

Type of product	EC106		
Date of purchase			
Name		Tel	
Address			

REVERSE OSMOSIS SYSTEM

EC106

USER'S MANUAL

- 01 Introduction of EC106
- 02 What is reverse osmosis
- 03 Components & Selected filters
- 04 Cartridge filters
- 05 The parts of EC106
- 06 Tubing connection diagram
- 07 Installation diagram
- 08 Change filters
- 09 Change membrane
- 10 Operation regulation
- 12 FAQ
- 14 Maintenance checking list
- 15 Memo

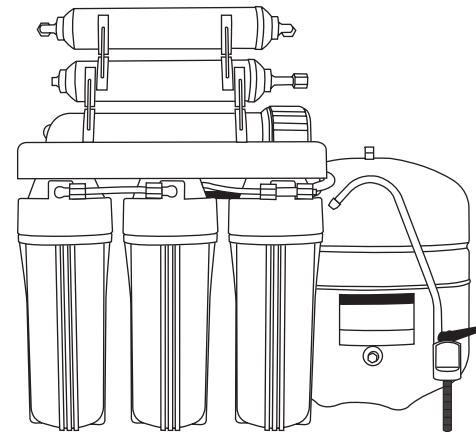

Thank you very much for selecting Pure-Pro Water Corp.
In order to bring the best use of your system, please read the user's manual carefully before installation and follow the regulations.

FAQ

Q: How will the Pure-Pro series water affect mixed beverages?

Because reverse osmosis removes invisible contaminants that mask flavor, it allows the natural taste of your beverages to come through. You will be able to use less coffee and still get the full flavor. Concentrated beverages like orange juice will taste tangier. You will probably be drinking a lot more water as well, since many people drink soda, Kool-Aid, concentrated juices, and beer as an alternative to bad-tasting tap water. Also, Pure-Pro eliminates most of the lime build up on drip coffee makers, preventing the need for frequent cleaning. No longer will you find the white scum on the inside of pans after boiling water.

Q: How much water does the Pure-Pro system produce ?

Under ideal conditions, the RE1812-70 TFC membrane is rated at 70gallons of production per day (70gpd at 60psi, 95gpd at 100psi). Under the average conditions, the consumer can expect 70-95 gallons of product water per day. But that's still a lot of water for the average household's drinking and cooking requirements.

Q: Don't people need minerals removed from the water ?

Most of the minerals that we receive are from the foods we eat. Only a very small percentage comes from the water we drink.

Q: What is the maintenance schedule for the Pure-Pro System ?

The three pre-filter cartridges should be changed every 6 months. The 5 micron sediment cartridge filter is the first one; the second is a carbon cartridge filter, and the third one is a 1 micron sediment filters. (some systems comes with the Extruded carbon filter.) Failure to change the cartridge every 6 months may cause chlorine to destroy the membrane.

What is reverse osmosis

Reverse osmosis was originally designed to make sea water drinkable for the navy. It is ideal for anyone on a low sodium diet. An R.O. membrane has a pore size much smaller than bacteria virus, or the cryptosporidium parasite. When functioning properly it will remove all microorganisms from tap water and produce sterile water. Reverse osmosis is the reversal of the natural flow of osmosis. In a water purification system, the goal is not to dilute the salt solution, but to separate the pure water from the salt and other contaminants. When the natural osmotic flow is reversed, water from the salt solution is forced to pass through the membrane in the opposite direction by application of pressure-thus the term REVERSE OSMOSIS. Through this process, we are able to produce pure water by screening out the salts and other contaminants.

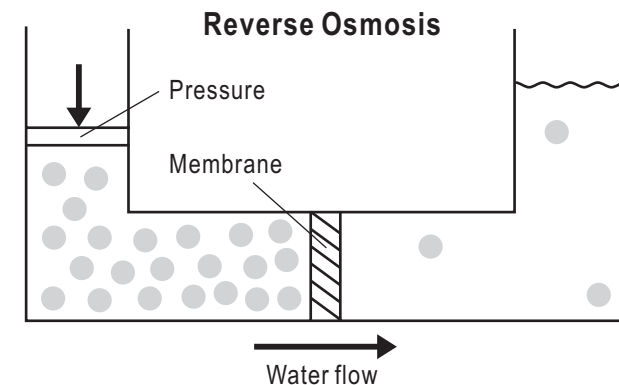

Components & Selected filters

◆ Components

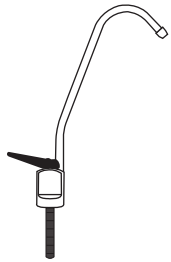

Standard faucet

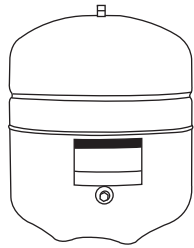

3.2G water storage tank



Housing wrench

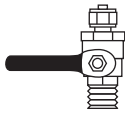

Deliver-valve

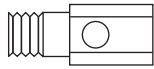

Water supply connector

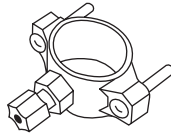

Drain saddle

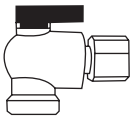

Tank ball shut-off valve

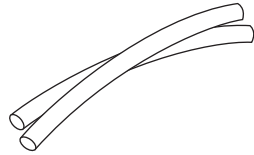

Four color coded 1/4 inch tubing for system connection

◆ Selected filters



Mineral cartridge filter

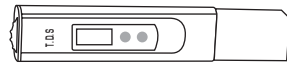

TDS meter



UV water sterilizer

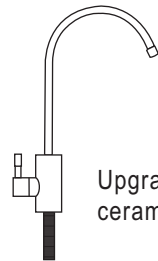

Upgraded european ceramic faucet

EC106 Upgrade Body Function RO System

FAQ

Q: What is the guarantee on the Pure-Pro system ?

The Pure-Pro System (excluding filters) is guaranteed for 1 year for material and workmanship. All defective parts will be replaced free within the first year under natural breakdown. The membrane has one year pro-rated guarantee.

Q: What factors affect the quantity and the quality of the water production?

There are four major variables to consider:

- 1. Pressure**-The greater the water pressure, the better water quantity and quality it produced. Water pressure of 60 PSI is ideal.
- 2. Temperature**-76°F is the ideal water temperature for R.O. 40°F water will cause the production of R.O. water to fall to half of that at 76°F. The maximum water temperature recommended is 85°F.
- 3. Total Dissolved Solids (TDS)**-The higher the amount of dissolved contaminants in the water, the lower the quantity of water produced. A high level of TOTAL DISSOLVED SOLIDS can be overcome with additional water pressure.
- 4. Membrane**-Different membranes have different characteristics. Some produce more water than others; some have better contaminant rejection capabilities; some have greater resistance to chemical abrasion for longer life. Pure-Pro system includes RE1812-70 The Thin Film Composite (TFC) membranes combine the best of these characteristics and are considered the finest membrane in the world.

Q: Can the Pure-Pro system be connected to an extra faucet?

It only takes a 1/4" tee and tubing to run the water to a refrigerator or a extra faucet. Some families run Pure-Pro system to all of their bathrooms.

Q: What does the Pure-Pro series drinking water taste like?

The taste of the Pure-Pro water depends on the amount of contaminants in the tap water originally. If 95% of dissolved minerals and chemicals are removed, the R.O. water may taste like distilled water (no minerals), bottled water (low mineral), or natural spring water (moderate mineral content).

EC106 Upgrade Body Function RO System







Operation regulation

- A. With everything connected, turn on the water check for leaks.
- B. Make sure the storage tank shut-off valve is "OFF". Open the sink top faucet.
- C. Within a few minutes (up to 15) the water will start to run from the faucet slowly.
- D. Let the water run for at least 30 minutes. This flushes the carbon filters on first time use.
- E. After initial flushing, open the shut-off valve on the tank and close the sink top faucet.
- F. Tank will now full of water (usually 2 to 3 hours) after the tank has filled. Open the sink top faucet and drain all water until the storage tank is empty and there is only a small flow from the sink top faucet. *** DO NOT USE FIRST TANK OF WATER. ***
- G. Close the sink top faucet. The system is now ready for use.
- H. Change filters regularly every 6 to 12 months and have the membrane checked annually.

Caution

1. Do not use hot water (over 45°C)!
2. Do not freeze the machine!
3. Switch off electricity and water source if away for more than 5 days, and drain out pure water.

Cartridge Filters

Cartridge Filters	Filter Description	Shelf life
Stage 1 5 Micron Sediment Filter 	This 5micron sediment filter is made of 100% pure polypropylene fibers. High capacity filter removes dusts, particles and rusts.	6 Months
Stage 2 Block Carbon Filter 	This block carbon filter is composed of high-performance carbon that removes free chlorine, odor, organic contaminants, pesticides and chemicals that contributed to taste and odor.	6 Months
Stage 3 1 Micron Sediment Filter 	This 1micron sediment filter is made of 100% pure polypropylene fibers. High capacity filter removes dusts, particles and rusts.	6 Months
Stage 4 TFC Membrane 	Made in USA. High rejection TFC type membrane with the capacity of producing 80 gallons per day. This membrane removes the following hard water contaminants that may be present in your water: lead, copper, barium, chromium, mercury, sodium, cadmium, fluoride, nitrite, nitrate, and selenium.	4 Years
Stage 5 Post Carbon Filter 	NSF approved. This post carbon filter is designed to improve taste. It removes any residual impurities and odors from the tank and provides a finer conditioning of pure water.	1 Year
Stage 6 Infra-Red Filter 	This Infra-Red filter can activate water molecules in our body and improve oxygen level in our body. Warm and eliminate fats, chemicals and toxins from our blood and thus smoothen the flow of blood.	1 Year

The parts of EC106

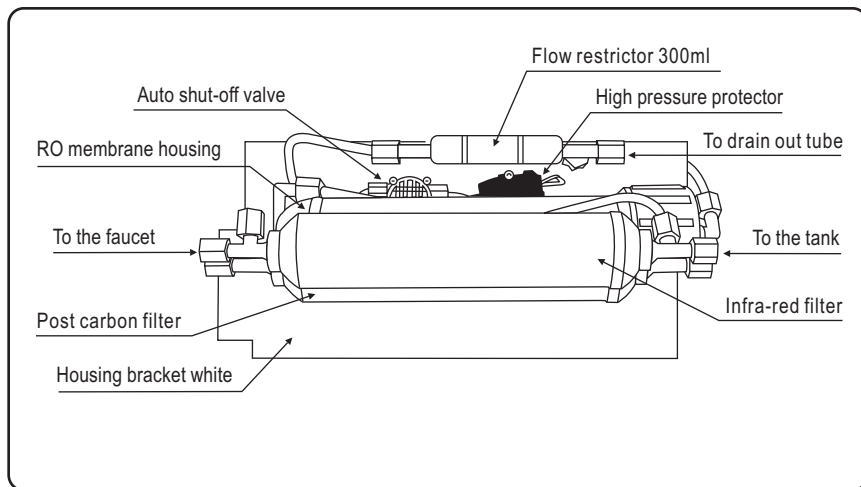
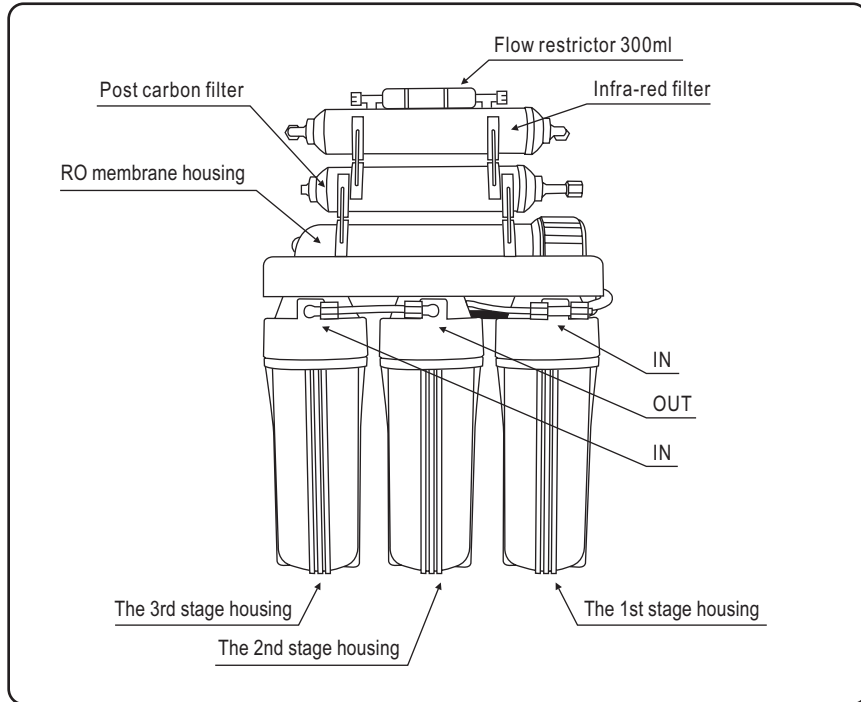

EC106 Upgrade Body Function RO System

Operation regulation

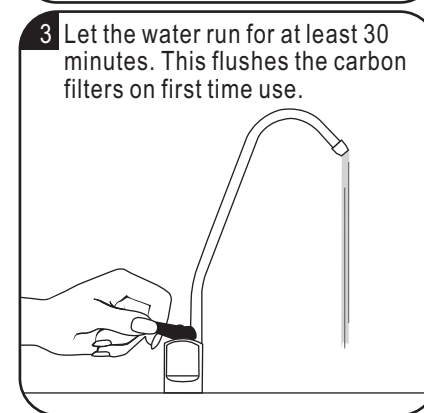
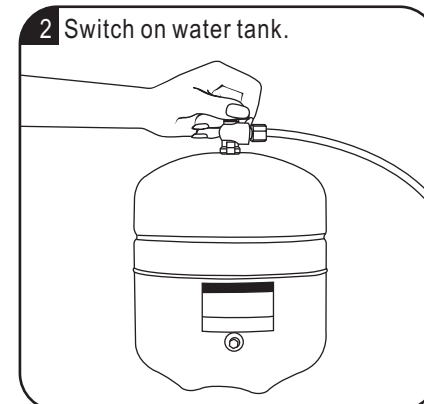
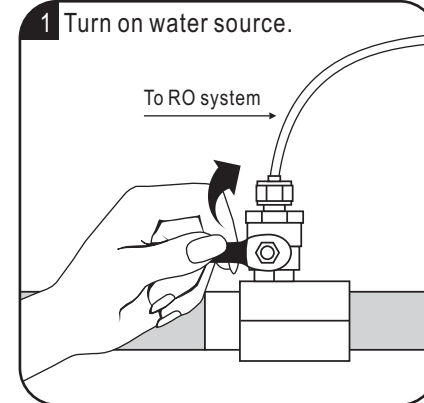

EC106 Upgrade Body Function RO System

Change membrane

1 Turn off water source.

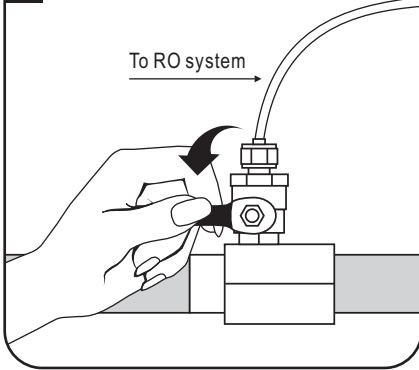

2 Switch off water tank.

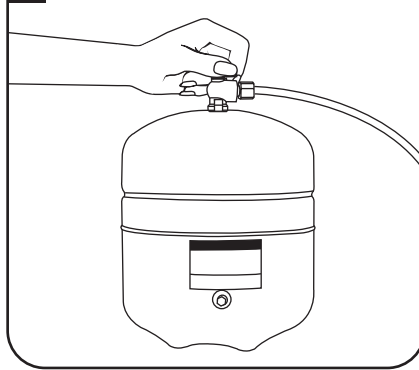

3 Loose the Joco fitting anticlockwise.

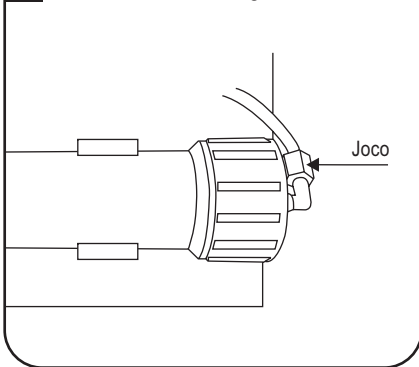

4 Remove the membrane housing cap anticlockwise.

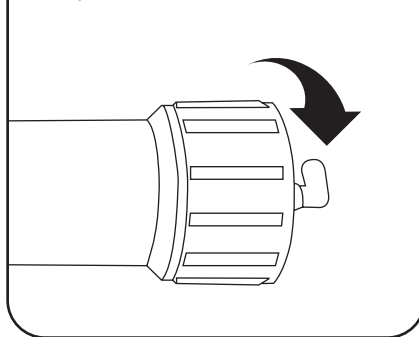

5 Remove the membrane by a pincer.

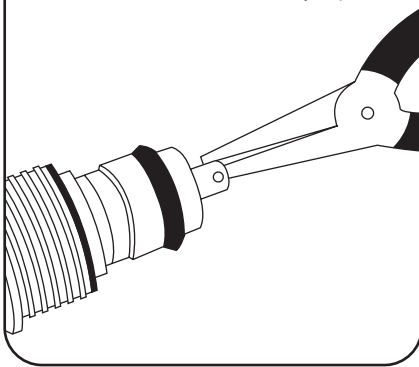

6 Install the membrane by carefully pushing the spigot end into the socket at the far end of the housing until completely in.

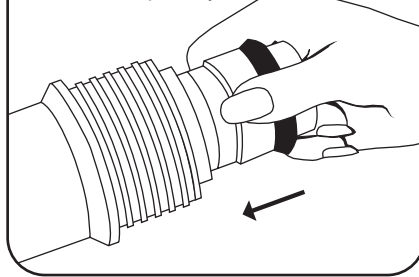

EC106 Upgrade Body Function RO System

PUREPRO
DRINKING WATER SYSTEM

Tubing connection diagram

CONNECTING THE COLOR TUBING:

- A. Connect the WHITE tubing to the water supply connector.
- B. Connect the BLUE tubing to the sink top faucet.
- C. Connect the BLACK tubing to the drain saddle.
- D. Connect the RED tubing to the storage tank.

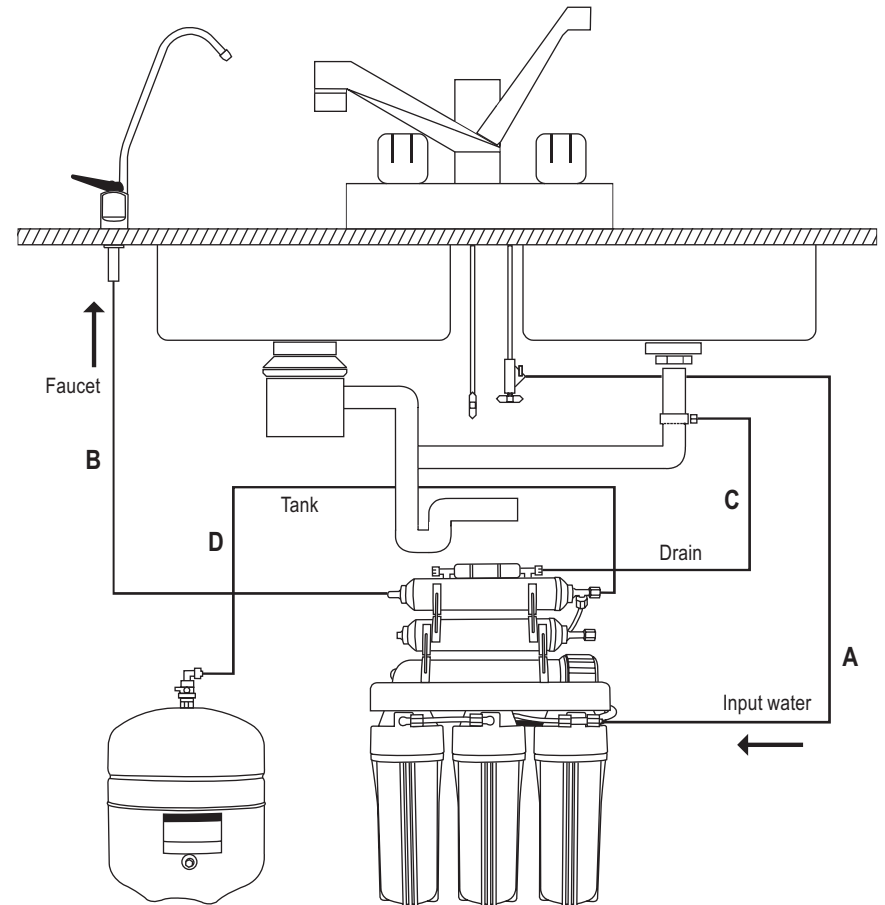

EC106 Upgrade Body Function RO System

PUREPRO
DRINKING WATER SYSTEM

Installation diagram

Input water :

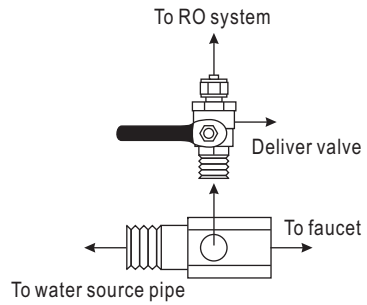

Install water tank :

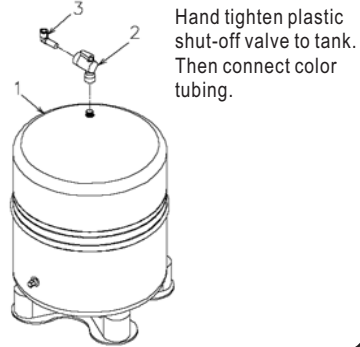

Install European ceramic faucet :

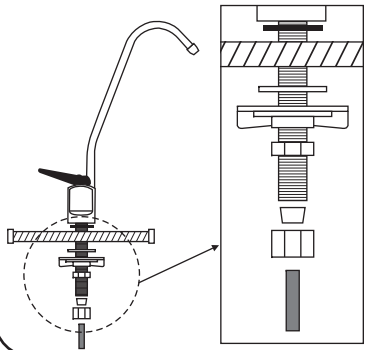

Install drain saddle :

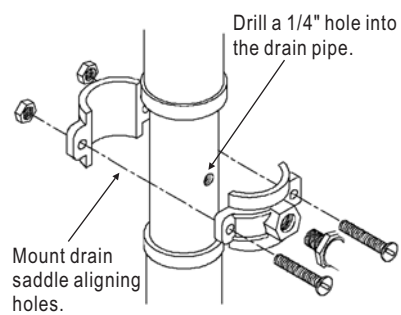

Assemble membrane :

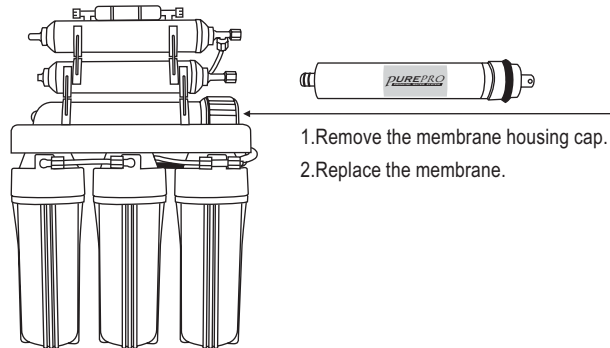

Change filters

1 Prepare a housing wrench.

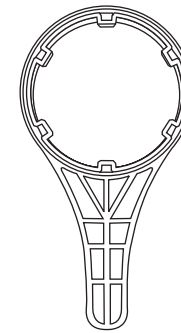

2 Turn off water source.

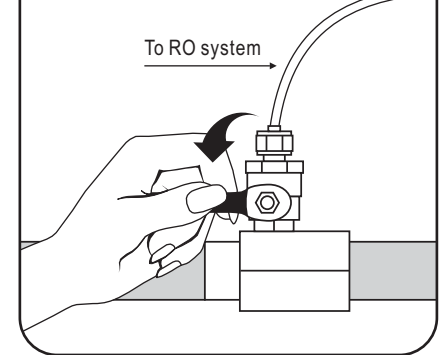

3 Switch off water tank.

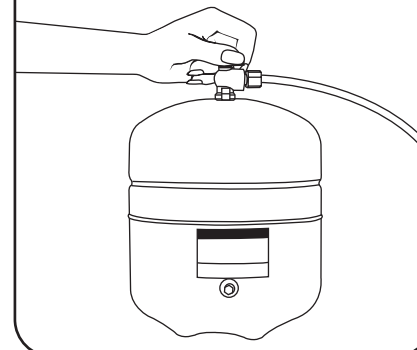

5 Open housings clockwise with a wrench.

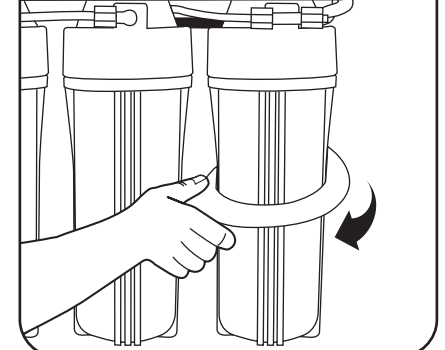

6 Put the replacement filters in the housings and double O' ring.

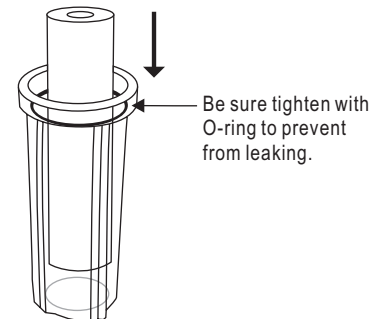

7 Drain out 1 Gallon of water to purify replacement filters.

